

Model : OWS-0502

Oil-water Separation Filter Unit HYDROTURN

Oil-water Separation Filter Unit

Nozzle number table

| NO, | 用途 | Size(Rc) |
|-----|----------------------------------|------------|
| N1 | Liquid inlet | 15A(Rc1/2) |
| N2 | process liquid outlet | 15A(Rc1/2) |
| N3 | Bleed air | 10A(R 3/8) |
| N4 | Oil water outlet for maintenance | 15A(Rc1/2) |
| N5 | Pressure gauge mounting port | 10A(R 3/8) |

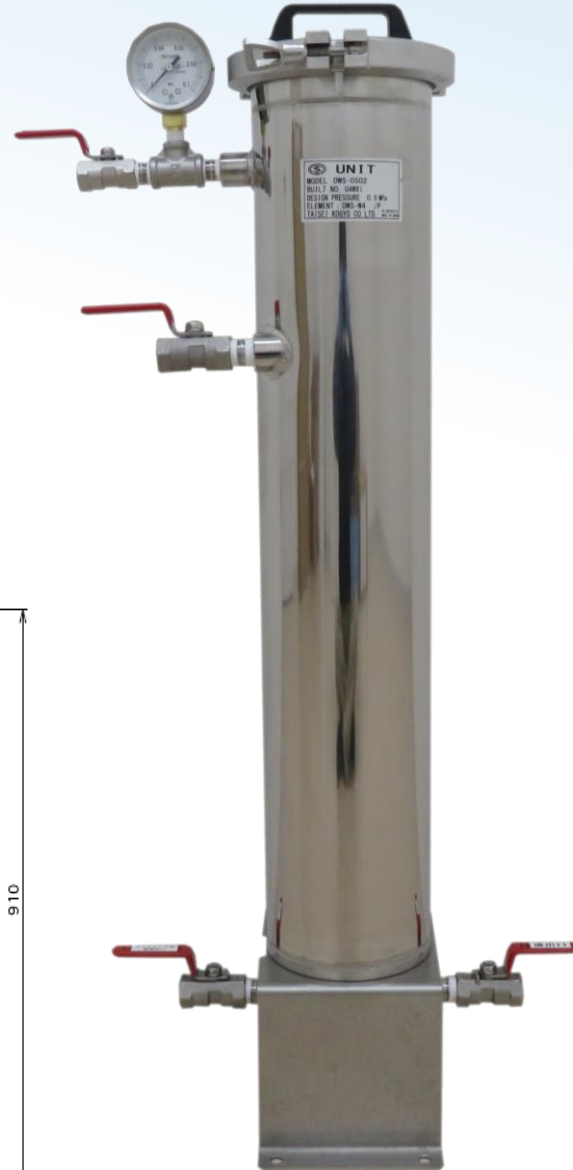

Element holder



To filter unit Mounting the element holder

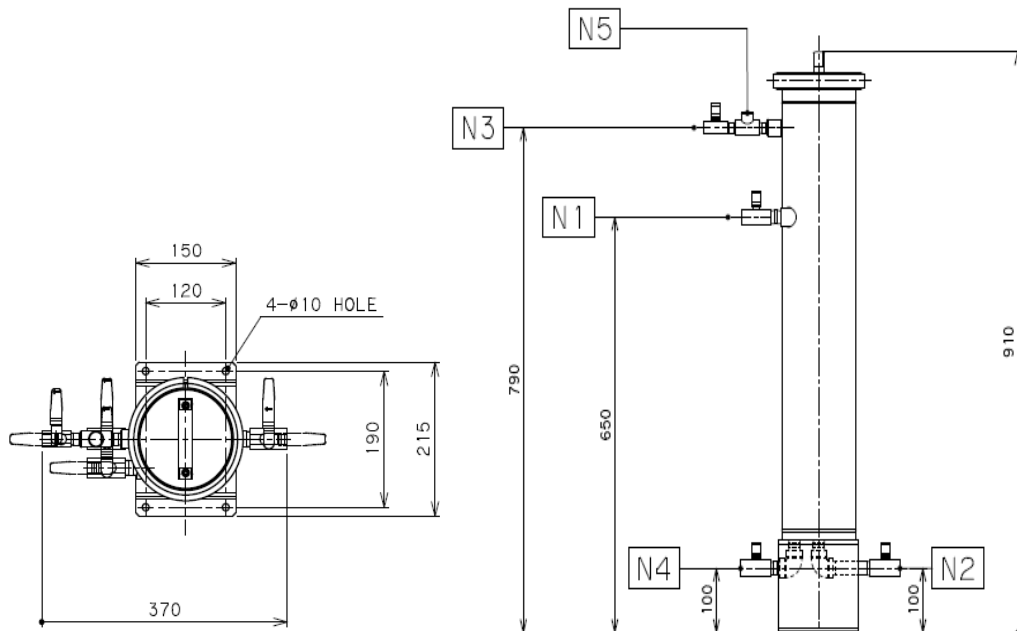

| | |
|--|------------|
| Main Unit Materials | SUS304 |
| Design Pressure | 0.3MPa |
| Design Temperature | 0~90°C |
| Number of Elements | 2本 |
| Capacity | 約8L |
| Weight | 18kg |
| Rough Dimensions (Body Diameter x Overall Height) | φ140×910mm |

※The unit shape in the images is an example.
Design and manufacture of these units according to your application is possible.

Model : OWS-1212

Oil-water Separation Filter Unit
HYDROTURN

Oil-water Separation Filter Unit

Nozzle number table

| NO, | 用途 | Size(Rc) |
|-----|--|--------------|
| N1 | Fluid inlet/maintenance oil water outlet | 50A(R 2) |
| N2 | Liquid outlet | 40A(R 1 1/2) |
| N3 | Bleed air | 10A(R 3/8) |

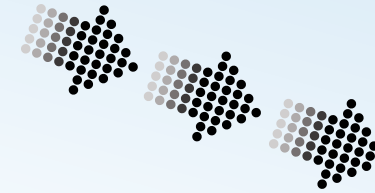

To filter unit Mounting
the element holder

Element holder



| | |
|--|------------|
| Main Unit Materials | SUS304 |
| Design Pressure | 0.3MPa |
| Design Temperature | 0~90°C |
| Number of Elements | 2本 |
| Capacity | 約8L |
| Weight | 18kg |
| Rough Dimensions (Body Diameter x Overall Height) | Φ140×910mm |

※The unit shape in the images is an example.
Design and manufacture of these units
according to your application is possible.

