

Model : OWS-0502/P

Oil-water Separation Filter Unit
HYDROTURN

Oil-water Separation Filter Unit(PVC)

Main Unit Materials	PVC
Design Pressure	0.3MPa
Design Temperature	0~50°C
Number of Elements	2本
Capacity	約7L
Weight	14kg
Rough Dimensions (Body Diameter x Overall Height)	φ140×860mm

※The unit shape in the images is an example.
Design and manufacture of these units
according to your application is possible.

Additional parts : Pre-filter unit
Model : PFU-101□/PP

Nozzle number table

NO,	用途	Size(Rc)
N1	Liquid inlet	15A(Rc1/2)
N2	process liquid outlet	15A(Rc1/2)
N3	Bleed air	10A(R 3/8)
N4	Oil water outlet for maintenance	15A(Rc1/2)



Element holder

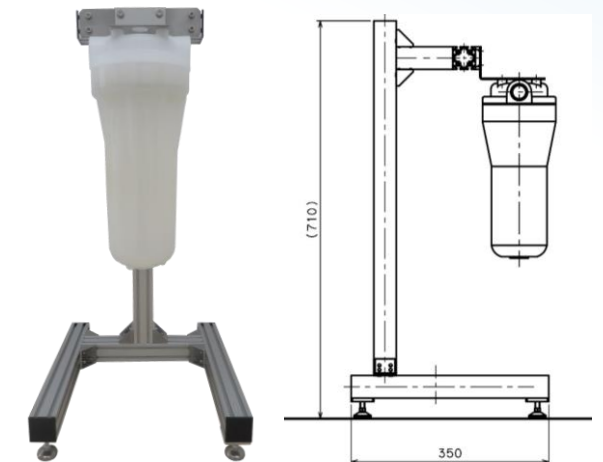
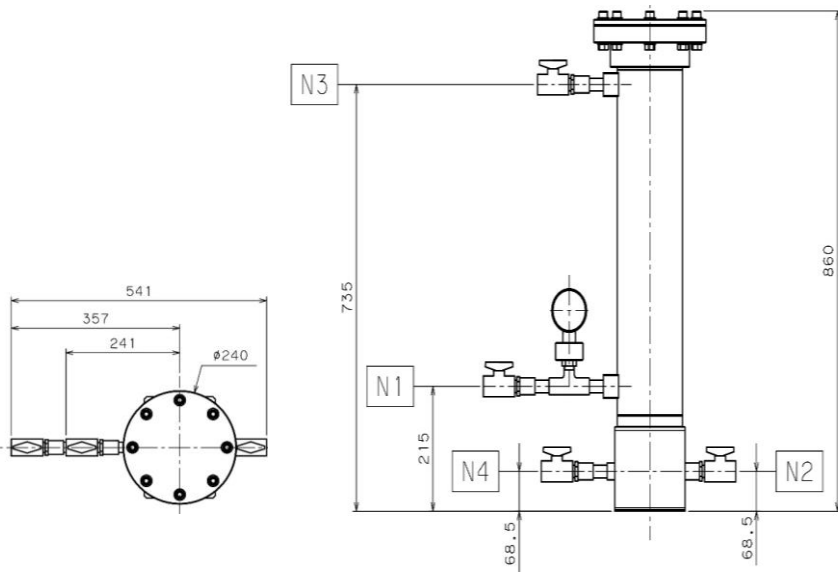

Model : OWS-0702/PP

Oil-water Separation Filter Unit
HYDROTURN

Nozzle number table

NO,	用途	Size(Rc)
N1	Liquid inlet	15A(Rc1/2)
N2	process liquid outlet	15A(Rc1/2)
N3	Bleed air	15A(Rc1/2)
N4	Oil water outlet for maintenance	15A(Rc1/2)
N5	Pressure gauge mounting port	15A(R 1/2)

Oil-water Separation Filter Unit(PP)



Main Unit Materials	PP
Design Pressure	0.3MPa
Design Temperature	0~50°C
Number of Elements	2本
Capacity	約9L
Weight	17kg
Rough Dimensions (Body Diameter x Overall Height)	Φ180×890mm

※The unit shape in the images is an example.
Design and manufacture of these units
according to your application is possible.

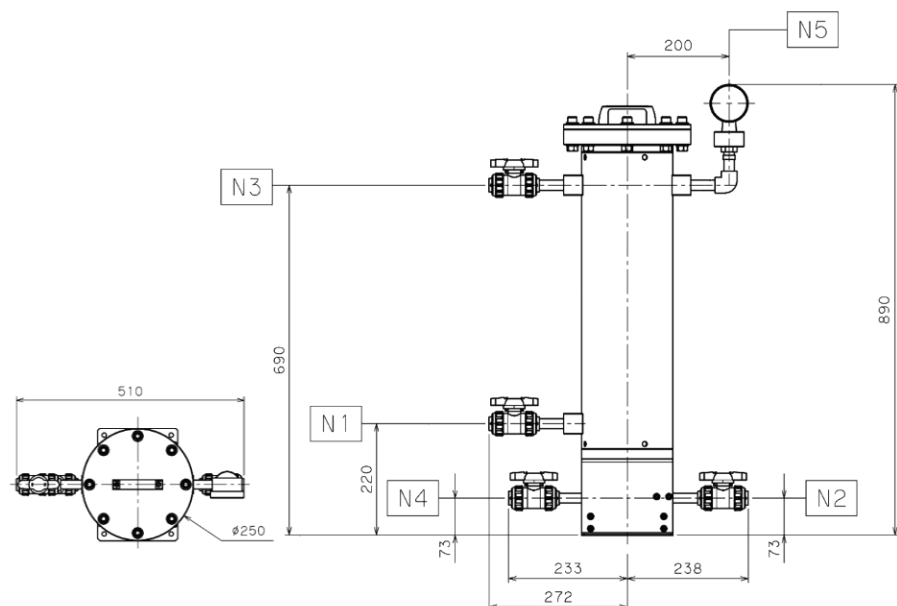

Element holder



Additional parts : Pre-filter unit Model:PFU-101□/PP

