

### Best-selling High Pressure Filter for construction machines

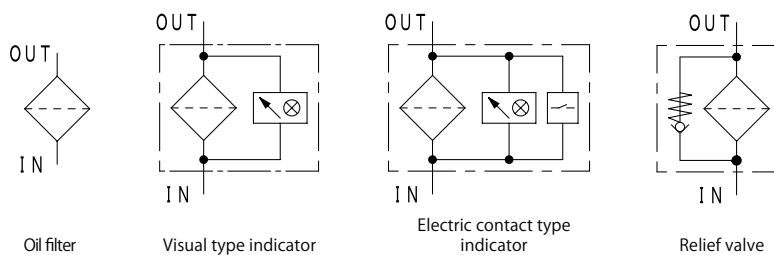

#### Characteristics

- Compact and downward extraction model for high pressure line  
Especially best for a system that hardly secures installation space
- Element size is selectable depending on flow rate and contaminant amount
- Clogging indicator and relief valve are selectable as an option
- High pressure element of allowable differential pressure 21MPa is available (standard: 0.7MPa)
- Pipe connection type is "G Thread"



★ Refer to P.222 for hydraulic graphic symbol of other combination of optional equipment.

### SPECIFICATION

Max working pressure	MPa	35.0
Repetition durability test		0~35.0MPa x10 <sup>7</sup> times
Working temperature	Standard	°C -10 ~ 90
	High temperature *1	°C -10 ~ 150
Indicator working pressure	Standard	MPa 0.3
	High pressure	MPa 0.7
Cracking pressure	Standard	MPa 0.35
	High pressure	MPa Non bypass
Allowable differential pressure of filter element	Standard	MPa 0.7
	High pressure	MPa 21.0
Flow direction/Extract direction of filter element		OUT → IN / Downward

Inner diameter		03A-2	03A-3	04A-2	04A-3	06A-2	06A-3
Standard flow rate ☆	ℓ /min	50	55	55	60	100	110
Main material	Body	FCD					
	Lower cover	Carbon steel					
Coating		Protective film treatment					
Weight	kg	6.3	7.4	6.3	7.4	6.4	7.5

☆ Standard flow rate is estimated by the condition of density: 0.86, kinematic viscosity: 32mm<sup>2</sup>/s, filtration rating: 10U, pressure drop: lower than 0.05MPa.

(Since it is adjusted by characteristic of each product, value can be different in some cases.)

★ Please prepare and use bonded seals when piping.

### MODEL CODE

<Model code example>



Code	Fluid type
Blank	Mineral oil
F	Phosphate ester fluid
G	Water glycol fluid
C	Fatty ester fluid
W	High water base fluid
S	Fuel (Kerosene, Gas oil, Diesel oil)
B	Brake fluid

Code	Inner diameter
03A	G 3/8 (10A)
04A	G 1/2 (15A)
06A	G 3/4 (20A)

Case length
2
3

Code	Filtration rating	Code	Filtration rating
C-Fiber		Wire gauze	
3C	3 μm	5UW	5 μm
8C	8 μm	10UW	10 μm
25C	25 μm	20UW	20 μm
High pressure C-Fiber		40UW	40 μm
3CH	3 μm	50UW	50 μm
8CH	8 μm	200W	200Mesh
25CH	25 μm	150W	150Mesh
Paper		100W	100Mesh
10U	10 μm	60W	60Mesh
20U *2	20 μm		
40U *2	40 μm		

Refer to P.15 -16 for detail information of filter element.

Code	Option
① Indicator	
Blank	Closing plug
I	Visual type
E	Electric contact type
D	Electric contact type (Micro capacity)
② Relief valve *3	
K	Non
V	Relief valve

\* 1 Sealing parts: FKM, only for wire gauze element, indicator and relief valve are not available (Max oil temperature is visual type: 130°C, electric contact type: 90°C)

\* 2 Not available for water-glycol based oil and high water based fluid      \* 3 Relief valve is not available if selecting high pressure element

# FLOW RATE GRAPH

## Condition

Fluid type : ISO VG32  
Oil temperature : 40°C

(Density: 0.86,  
Kinematic  
viscosity: 32mm<sup>2</sup>/s)

## How to calculate of pressure drop

Estimate pressure drop of filter assembly by following equation:

$$\text{Pressure drop of filter assembly} = \text{① Pressure drop of filter housing} + \text{② Pressure drop of filter element}$$

Estimate pressure drop of filter assembly by following equation if required condition is different:

$$\begin{aligned} \text{Pressure drop of filter housing} &= \frac{\text{Fluid density}}{0.86} \times \text{Pressure drop of filter housing at density of 0.86} \\ \text{Pressure drop of filter element} &= \frac{\text{Fluid density}}{0.86} \times \frac{\text{Kinematic viscosity}}{32} \times \text{Pressure drop of filter element at density of 0.86, kinematic viscosity of 32} \end{aligned}$$

★ Pressure drop of filter housing is proportional to fluid density, and pressure drop of filter element is proportional to fluid density and kinematic viscosity.

### ① Pressure drop of filter housing

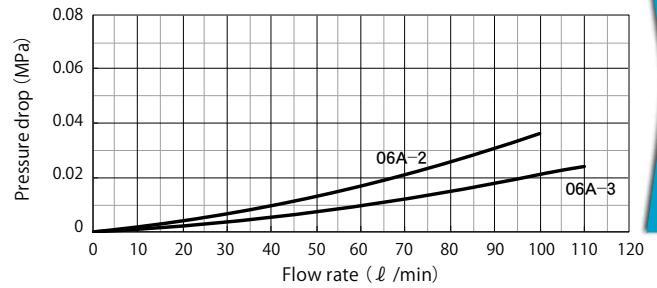
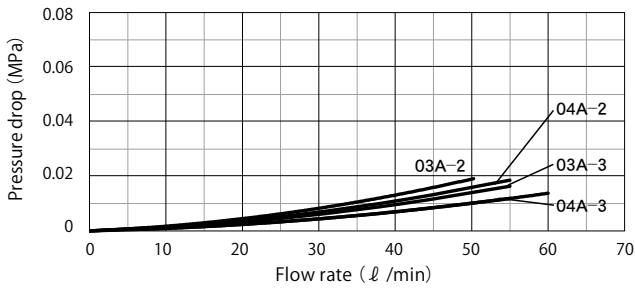

### ② Pressure drop of filter element

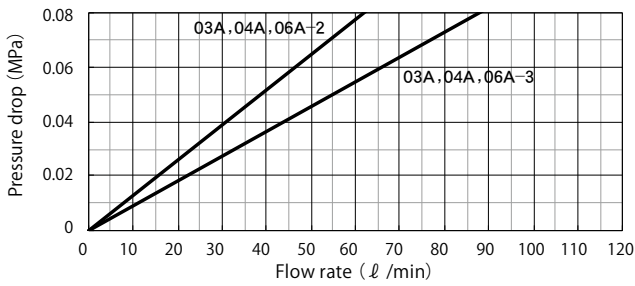

**3C**  
3 μm

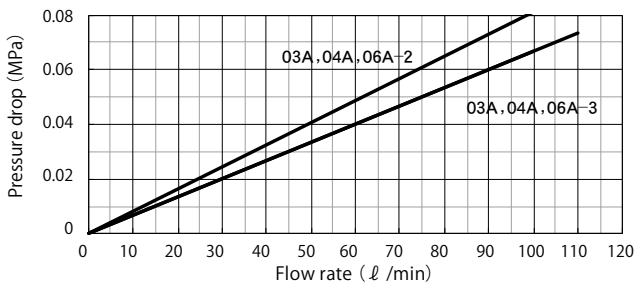

**8C**  
8 μm

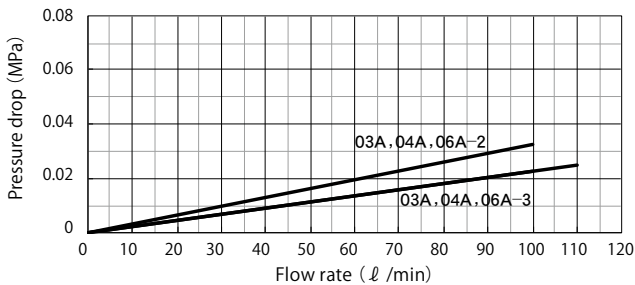

**10U**  
10 μm

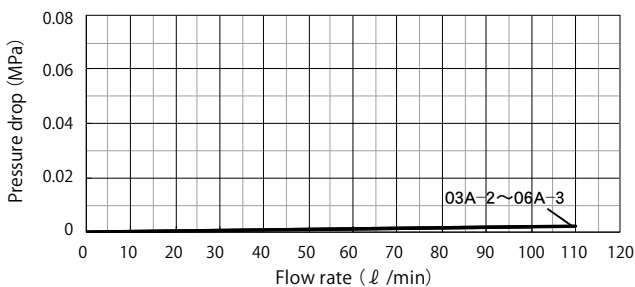

**150W**  
150 Mesh\*

\* 1 Pressure drop of wire gauze element is described with one line since the value is low and there is no difference at each filter size.

3501-03A,04A-2-I□

I: Visual type indicator

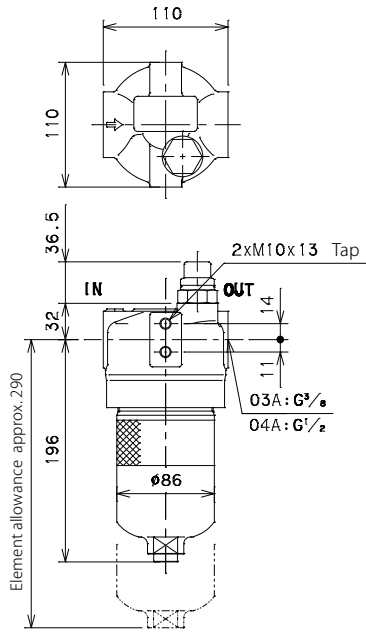

3501-03A,04A-3-I□

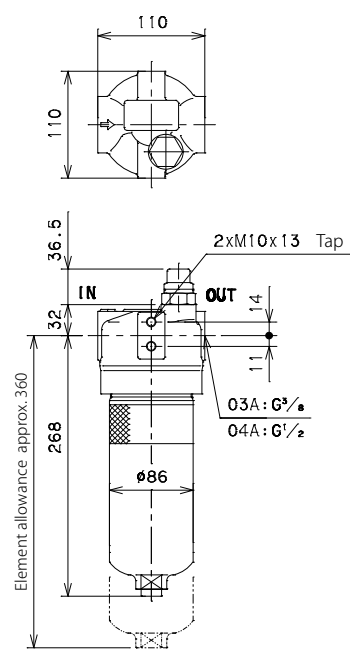

3501-06A-2-I□

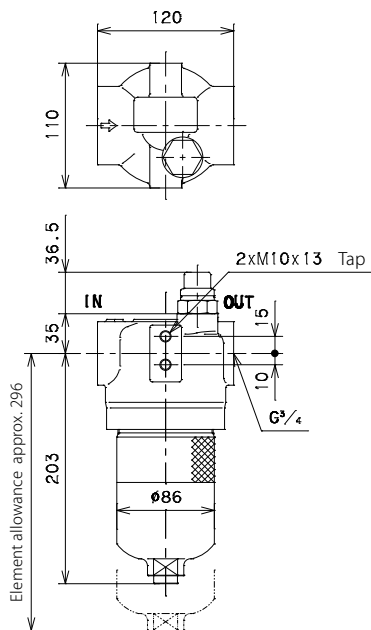

3501-06A-3-I□

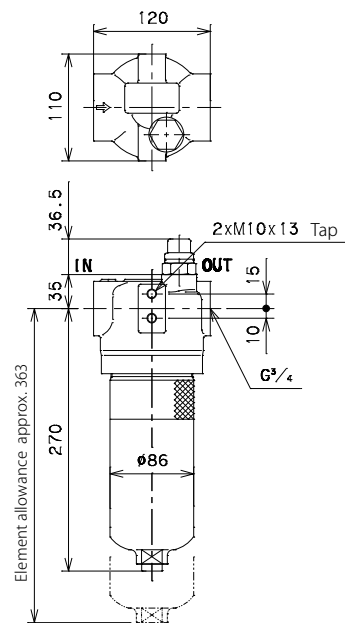

Differential pressure type indicator part  
\* Common at all size

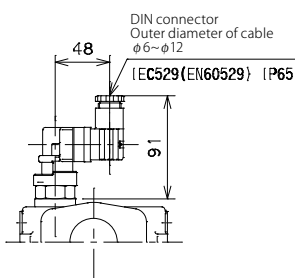

E,D: Electric contact type indicator  
3501-□□-□□-□□-ED□

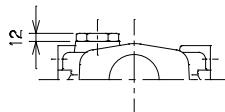

Closing plug  
3501-□□-□□-□□-□□

Model code	Working pressure(MPa)		
	Visual observation signal		Electric signal
	Caution	Clogging	
IF-3	0.2	0.3	/
IF-7		0.7	
EF-3		0.3	0.3
EF-3D			
EF-7		0.7	0.7

<Micro switch specification>

Model code	Rated capacity	Contact diagram : 1C	
		1 . COM	2 . NC
EF-3 EF-7	Resistance load 3A,250V AC 3A,30V DC Inductive load 2A,250V AC 2A,30V DC		
EF-3D EF-7D	Micro capacity 100mA,125V AC 100mA,30V DC		

★ IF-7 and EF-7(D) are for High pressure element.

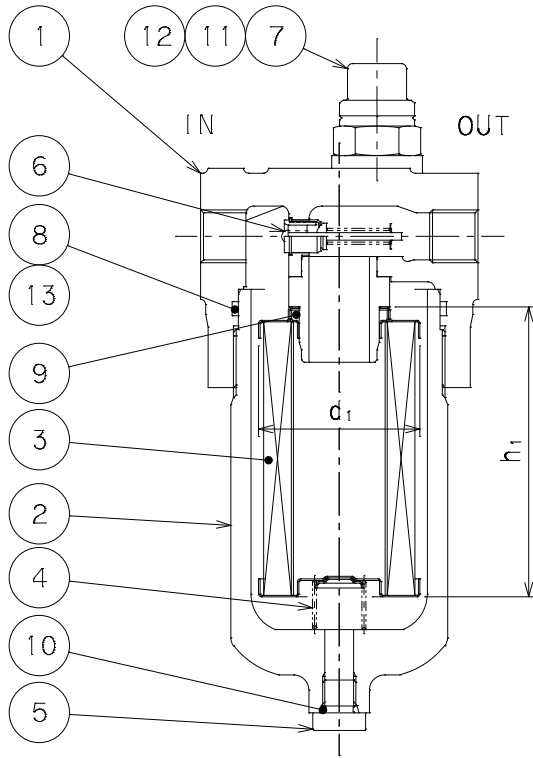

No.	Item	Qty
1	Body	1
2	Lower cover	1
3	Element	1
4	Spring	1
5	Drain plug	1
6	Relief valve	1
7	Indicator	1
8	O-ring	1
9	O-ring	1
10	O-ring	1
11	O-ring	1
12	O-ring	1
13	Backup ring	1

ELEMENT SIZE

Element Model code	Size(mm)			Weight*1 (kg)
	$\phi$ d <sub>1</sub>	h <sub>1</sub>		
		High pressure		
P-3501-2	64	115.0	115.3	0.22
P-3501-3		182.0	182.3	0.32

SEALING PARTS LIST

No.	8	9	10	11	12	13	Item code of sealing parts set*3				
	Standard*2	JIS B2401 1B	JIS B2401 1A	JIS B2401 1B	JIS B2401 1A	JIS B2407 T3	Material	SP No.: 8 ~ 10, 13	SP-H No.: 8 ~ 10, 13	SA No.: 8 ~ 13	SA-H No.: 8 ~ 13
3501-03A,04A,06A	G80	P32*4	P11	P18	P14	For G80	NBR	SSF000105	SSF000109	SSF000102	SSF000106
							FKM	SSF000472	SSF000479	SSF000469	SSF000473

MODEL CODE OF SPARE PARTS

Replacement element (Model code example)

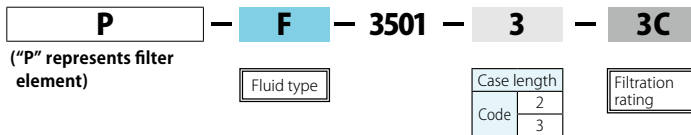

★ Model code of replacement element exists two types: "Individual code" and "Common code", however it represents same product.

"Individual code": Used in drawings and nameplate as shown in <Model code example>.

"Common code": Used in vouchers and tag Refer to [Spare Element List] on P.152 for "Common code".

Sealing parts set (Model code example)

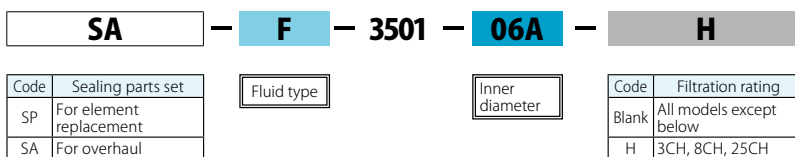

★ Refer to the [MODEL CODE] table on the previous page for code selection.

\* 1 Weight of "Paper" element \* 2 Standard for NBR. For other material, conform to the standard.  
 \* 3 Sealing parts are available as "Sealing parts set" only. We do not provide single part individually.  
 \* 4 Backup ring (P32) is attached for high pressure element (JIS B2407.T3)